

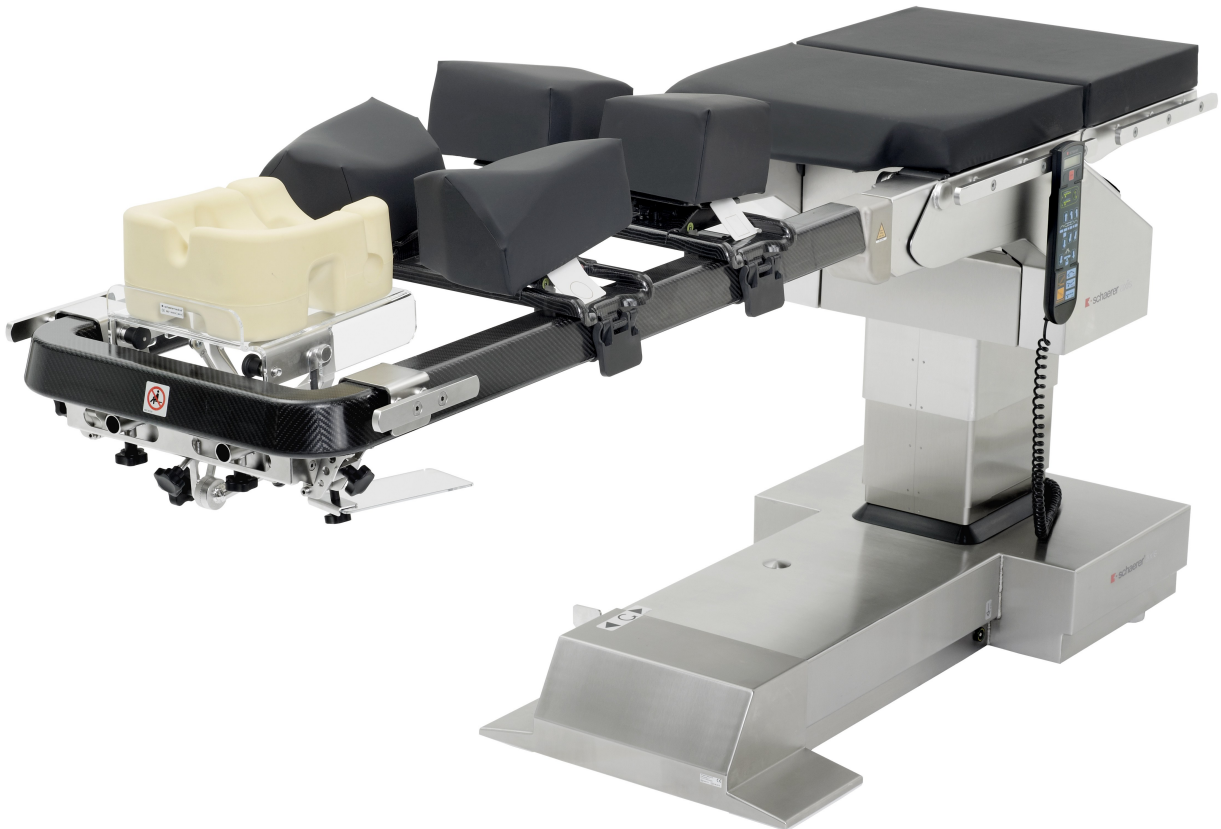

Carbon Spine Frame

MOBILITY AND ACCESSIBILITY FOR PRONE POSITIONING



Swiss Innovation & Precision

Carbon Spine Frame (CSF)

The Carbon Spine Frame (CSF) is an innovative solution from Schaerer Medical for prone positioning. The four-pads support distributes the weight over the chest and pelvic area, which enables a free abdomen. In combination with an Axis or Arcus

operating table, the system has a cantilevered design that allows optimized access for staff and equipment such as O-rings and C-arms. The design also allows for patient transportation and intraoperative adjustments of the patient position.

Benefits at a glance

- Access for anesthesia staff, equipment, O-rings and C-arms
- Perioperative motorized tabletop adjustments
- Individual adjustments for free abdomen
- Supports comfortable working
- No floor Support needed
- Large 3D X-ray window



Four-post positioners

Individual adjustment of lateral position and angulation of the pads by one-touch release. Adaption for tall patients by longitudinal adjustment of the pad holders. The anatomically shaped viscoelastic pads for male and female

patients solid support during surgery and enables free abdomen. With a maximal patient weight capacity of 240 kg / 529 lbs (Arcus), 200 kg / 441 lbs (Axis).

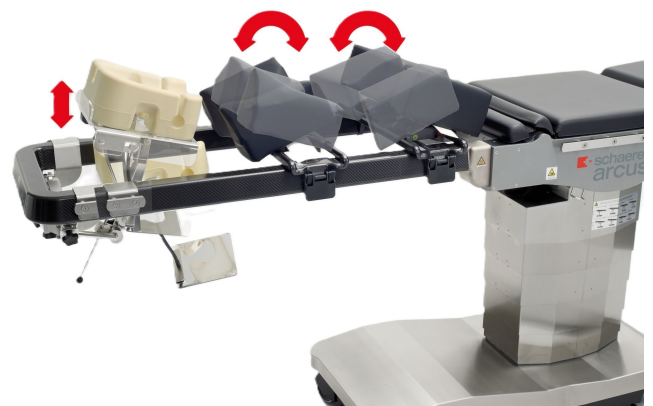
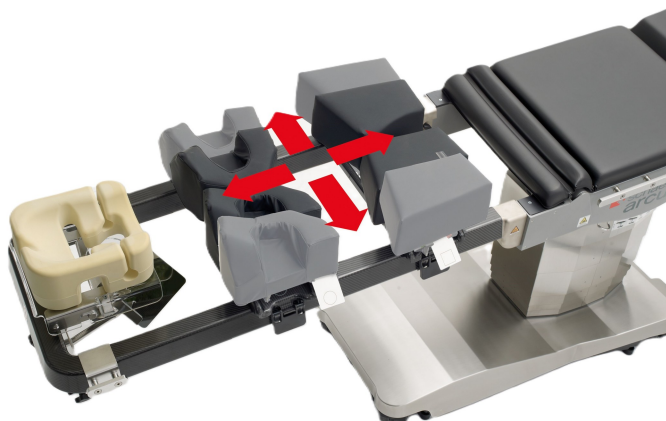

Siège: 27, Old Gloucester Street, LONDON, WC1N 3AX, (UK) - Tél. +44 20 3398 1339

Bureaux: 15 rue de la Garenne 27950 Saint-Marcel (France) Tél. +33 1 87 66 35 60

<https://ibsgroupe.com> – Email: dircom@ibsgroupe.com

Turnkey Supplier

Perioperative motorized tabletop adjustments

Carbon Spine Frame does **not** require a Floor support. The tabletop can be moved while the patient is positioned on the frame without adjusting any Floor support. The motorized joint moves

the tabletop to a flex or reflex position even during surgery. The low minimum height provides an ergonomic working position for the surgeon and enhanced access to the patient.



Access for anesthesia, O-ring and C-arms

Another advantage of the Carbon Spine Frame is the high accessibility for the anesthesia, O-ring and C-arms. A transparent head plate and flexible mirror ensures visibility to the head of the patient at all times.

The head rest clamp allows to connect DORO® and MAYFIELD® accessories



Large X-ray window

The Carbon Spine Frame is radio transparent in a range of 1315 mm / 51.7 inch. It offers access for even two C-arms at the same time.

Patient transportation

Thanks to the design of the Carbon Spine Frame, the positioned patient can be transported from the preparation area to the operating room.



Siège: 27, Old Gloucester Street, LONDON, WC1N 3AX, (UK) - Tél. +44 20 3398 1339

Bureaux: 15 rue de la Garenne 27950 Saint-Marcel (France) Tél. +33 1 87 66 35 60

<https://ibsgroupe.com> – Email: dircom@ibsgroupe.com

Turnkey Supplier

System Overview

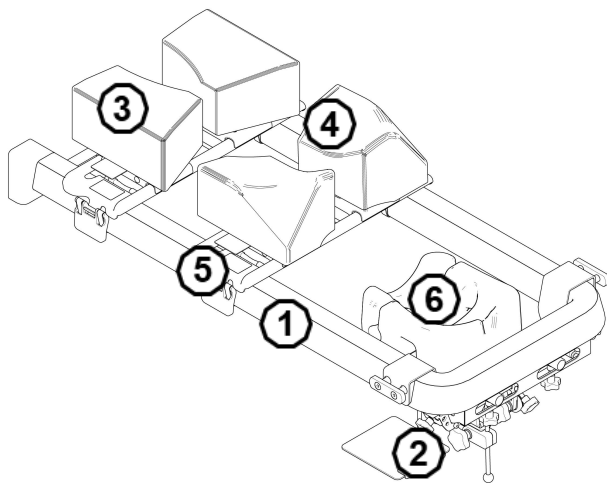

- ① Carbon Frame
- ② Head rest clamp including mirror
- ③ Pelvic pads
- ④ Chest pads
- ⑤ Cross bar with pad holder
- ⑥ Head positioning device

Weight Basic set	17.6 kg / 38.80 lbs
Weight carbon frame only	6.2 kg / 13.66 lbs
Patient weight capacity	
Schaerer Axis 500/700	200 kg / 441 lbs
Schaerer Arcus 501/701	240 kg / 529 lbs
Pad adjustment	+ / -15°

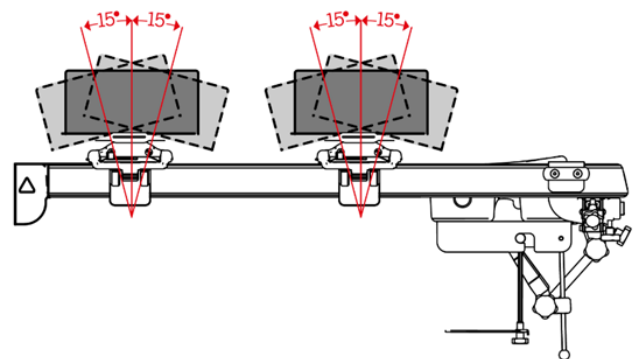

Overall length	1205 mm / 47.44 in
Length 360° radiolucent	805 mm / 31.7 in
Frame length	1052 mm / 41.41 in
Width frame	480 mm / 18.89 in
Width frame including head rest clamp	580 mm / 22.83 in

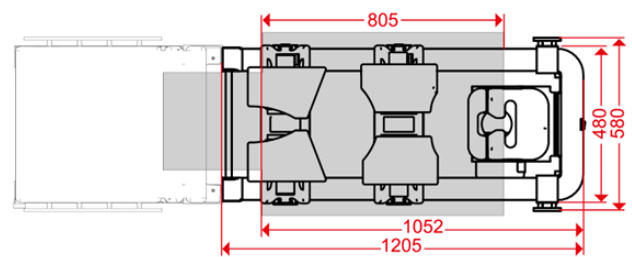

Carbon Spine Frame (CSF)

Basic system includes: carbon frame, head rest clamp including mirror, 2 male, 2 female chest pads, 2 pelvic pads (unisex) and pad holders.

Siège: 27, Old Gloucester Street, LONDON, WC1N 3AX, (UK) - Tél. +44 20 3398 1339
 Bureaux: 15 rue de la Garenne 27950 Saint-Marcel (France) Tél. +33 1 87 66 35 60

Turnkey Supplier

<https://ibsgroupe.com> – Email: dircom@ibsgroupe.com