

# X-FRAME DR2S SYSTEM

Chest and General X-Ray DR system



---

## PRODUCT DATA

# Product data

X-FRAME DR2S SYSTEM – Rev.9

	Page
Description and Configurations	3
Technical Features	16
Digital Workstation	16
Generator – X-ray tube	18
STATIX Column Tube Stand	20
BS45 Vertical Stand	21
BTE elevating table	21
Accessories	22
Size and Dimensions	23
Classifications	27
Installation and warranty	27

## DESCRIPTION

### X-FRAME DR2S SYSTEM: DUAL DETECTOR SYSTEM FOR CHEST AND GENERAL RADIOGRAPHY

ITALRAY DR SOLUTIONS is a complete range of digital radiography rooms and represents the perfect solution for modern Radiology Departments, for both General Radiography and Trauma. Thanks to the extreme modularity and full automation of the ITALRAY DR architecture, customers can rest assured that there is an ITALRAY DR system that perfectly fits all four main department needs:

**CONNECTIVITY:** use of Radiology Information Systems (RIS) and Picture Archiving and Communications Systems (PACS) for a full distribution of images and exam information throughout the Hospital

**PRODUCTIVITY:** optimization of department operating costs thanks to the high efficiency and examination speed of ITALRAY DR systems

**DOSE REDUCTION:** significant reduction of patient dose thanks to the Flat Panel Detector technology with extremely high sensitivity and dynamic range

**IMAGE QUALITY:** see details and anatomical structures with detail and contrast resolution levels unachievable with film or CR.

ITALRAY X-FRAME DR2S SYSTEM is a high productivity system for General and Chest examinations, with minimal space requirements, with the following configuration:

- ITALRAY **PIXEL HF TS** X-ray Generator
- ITALRAY **STATIX** Synchro column tube stand
- ITALRAY **BS45** Vertical Stand with Flat Panel Detector
- ITALRAY **BTE** a radiographic 4-way elevating table with Flat Panel Detector
- ITALRAY **X-FRAME DR** Digital Acquisition Workstation

With ITALRAY X-FRAME DR2S SYSTEM, flexibility and performances are granted in any application: projections with patient in horizontal/vertical position, Chest exams with minimum patient-detector distance, and examinations with grid removal.

## DIGITAL RADIOGRAPHY: UNSURPASSED IMAGE QUALITY

ITALRAY X-FRAME DR2S SYSTEM is based on the solid-state detectors, featuring amorphous Silicon (a-Si) technology and Gadolinium (Gadox) or Cesium Iodide (CsI) scintillator: a combination that is the de facto standard in medical imaging and guarantees high quality X-ray images for immediate diagnosis, in real time and with low exposure. Images are acquired with a minimum pixel pitch thus producing brilliant images with an extremely sharp resolution matrix. In addition, thanks to the 16 bits grayscale acquisition depth and the very-low-noise electronics, an incredible grayscale dynamic range is guaranteed, and even the most subtle details and the most diverse structures can be effectively identified in only one image, with image retakes practically eliminated.

With 43x43 cm detectors, the largest active areas available on the market today, any anatomical district can be imaged, even in presence of tall/corpulent patients.

## MAXIMUM SYSTEM FLEXIBILITY WITH WIRELESS CASSETTE-SIZE FLAT PANEL DETECTOR (OPTIONAL)

ITALRAY X-FRAME DR2S SYSTEM increases its versatility with the possibility to use a wireless cassette-size detector instead of the fixed one, into the bucky table (BTE).

This innovative wireless flat panel features amorphous Silicon (a-Si) technology and a Caesium Iodide (CsI) scintillator and grants for brilliant images with extremely sharp resolution, on a wide active area (35x43 cm) with an important reduction in dose exposure.

It is also battery powered and employs wireless image data transmission, thus freeing the room from cumbersome and risky cables for an unlimited operation autonomy.

Cassette-size detector is removable from the potter, for out-of-bucky examinations directly in contact with the patient, either on a bucky table or on a stretcher, always communicating with the digital workstation in a **Wi-Fi mode**. A dedicated BTE accessory for wireless detector allows lateral projections for patient laying on the table.

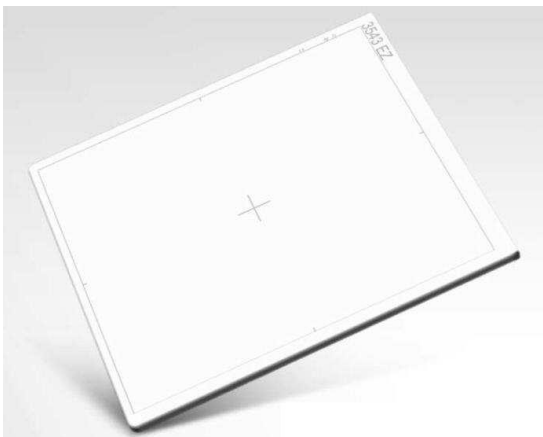

Cassette size (35x43 cm) wireless detector

Two important features characterize this innovative flat panel detector:

- Auto-triggering with x-ray generator: the images acquisition start without any physical synchronization with x-ray generator, just once the x-ray emission is "felt" by detector
- Internal memory for automatic image storage (about 80 images).

These important features allow to use this wireless flat panel anywhere out of fixed digital radiography room, it's enough to have an x-ray generator and X-Frame DR software (either on a computer or on a tablet), dedicated to image acquisition and communicating with the detector in a wireless mode, to perform any kind of examinations.

## **HIGH DQE, LOW DOSE**

The Cesium Iodide (CsI) scintillator provides a very efficient X-ray absorption, which guarantees reduced patient dose, while fiber-optic-communication, between detector and workstation, provide diffusion-free high quality images. The Gadolinium scintillator is a proven and reliable technology for all-around applications.

For reporting purposes, the system can be equipped with a Dose Area Product (DAP) meter (optional), and the measured dose is automatically stored into the image DICOM file header.

## **400 kHz X-RAY GENERATOR OUTPUT FOR MAXIMUM IMAGE CLARITY**

ITALRAY PIXEL HF TS X-ray generator is capable of a tube output frequency up to 400 kHz. Thanks to this feature a very high X-ray beam quality is guaranteed at all load conditions. After all, image quality does start with a good X-ray source.

Furthermore, PIXEL HF TS automatically selects the most appropriate anode rotation speed (3.000 rpm or 9.000 rpm, with optional HSS) for the specifically selected load according to the chosen examination: by doing this, useless X-ray tube wear is avoided and X-ray tube life maximized.

## **AUTOMATICALLY DOWNLOADED WORLIST PATIENT DATA FROM RIS**

Thanks to the X-FRAME DR2S SYSTEM seamless RIS worklist integration (Radiology Information System) the operator has all the necessary exam information (patient name, exam type, accession number, etc.) even before the patient walks in, and no time is wasted for data entering procedures, with all data-entering-related problems and errors virtually eliminated.

Also, when an exam is initiated without a worklist entry (e.g. trauma exam), the resulting study can be reconciled at a later moment with the appropriate RIS entry created for the new patient.

## **AUTOMATIC SINGLE PATIENT MULTI-EXAMINATION GROUPING**

Oftentimes, when a single patient is scheduled to perform more than one examination, the RIS system will create multiple worklist entries, one for each examination. This can lead to workflow problems: as a matter of fact, in the typical fast-paced radiology department, it is easy for the operator to overlook the fact that the individual patient in the exam room has further examination scheduled and it can happen that the patient goes back to the dressing room and then home without having all the planned examinations performed.

To overcome this simple yet very common problem, X-FRAME DR2S SYSTEM, when there is more than one examination scheduled for a single patient, groups all the examinations together, thus highlighting the multiple exams and ensuring that all the necessary images are taken and that nothing goes unchecked.

## INTUITIVE GRAPHICAL USER INTERFACE

The X-FRAME DR2S SYSTEM Graphical User Interface (GUI) has been designed with operator needs in mind. The layout is simple and intuitive and the operator is guided step-by-step during all the image acquisition process and exam procedure. All relevant imaging and exam parameters are displayed on the screen and system status is verifiable at a glance.



Simple and intuitive, the X-FRAME DR2S SYSTEM Graphical User Interface shows all relevant exam information and allows a fast and efficient operation.

## INTEGRATED OPERATOR CONSOLE WITH MICROPHONE (OPTIONAL)

ITALRAY X-FRAME DR2S SYSTEM can be equipped with an integrated operator console with dedicated function buttons for the most common operations, integrated X-ray emission button, and microphone to communicate with the patient in the room during the examination.

## INTEGRATED X-RAY GENERATOR CONSOLE

The PIXEL HF TS X-ray generator console is now integrated in the acquisition workstation. This allows a higher degree of integration between power generation and image acquisition, allowing the operator to focus his/her attention to only one system console, thus making his/her work easier and more efficient. In addition, it frees up precious desk space.

### X-RAY PARAMETERS AND SYSTEM MECHANICAL POSITIONS AUTOMATICALLY SET ACCORDING TO EXAM TYPE

When the patient enters the exam room, the entire system is already prepared to go: thanks to the direct interface with the ITALRAY PIXEL HF TS generator, all exam-specific and patient size-specific X-ray parameters are correctly predisposed, and acquisition parameters and curves are already appropriately set on the acquisition workstation. The operator can choose to work with the Automatic Exposure Control system or in manual technique, and this choice can be associated with each existing imaging protocol or incorporated into a newly created one. The system mechanical configuration is also verified to avoid wrong exposures.

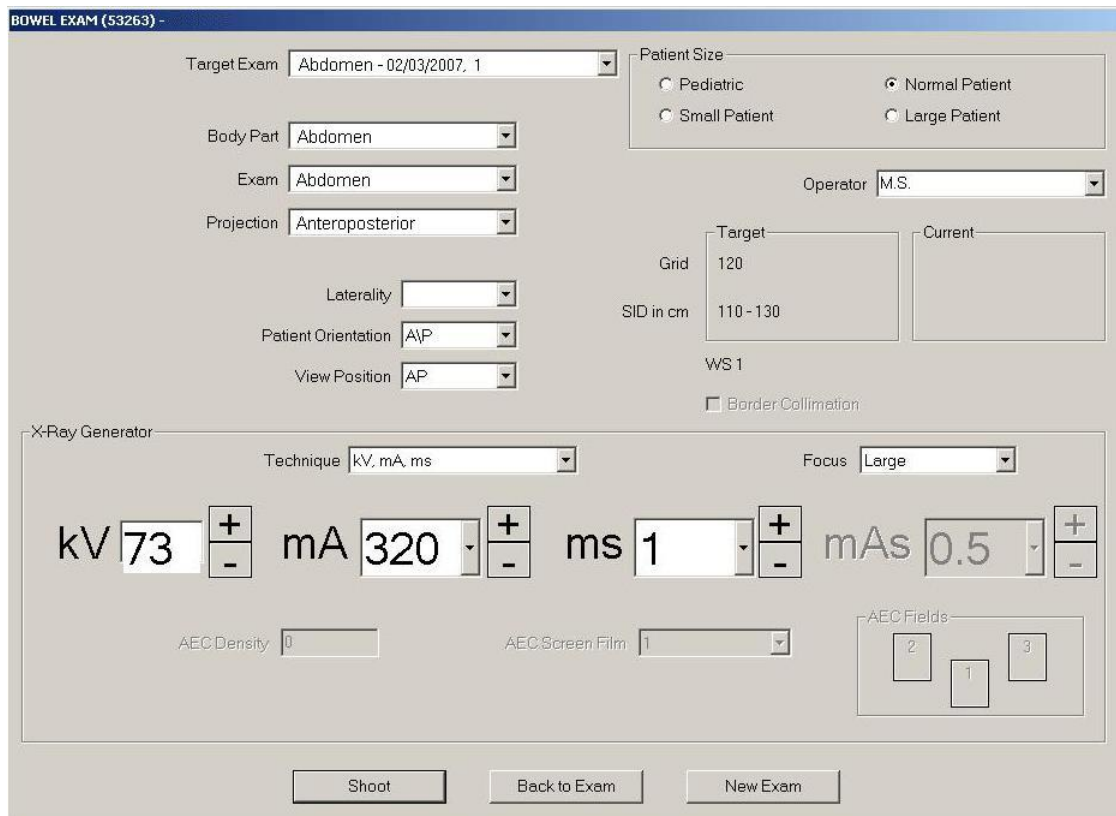

### EXAM-SPECIFIC AUTOMATIC COLLIMATION

According to the selected examination, patient size, and focal distance, exact collimation is automatically set thanks to the motorized collimator; electronic collimation makes sure that only the significant portion of the image will be displayed (this feature is an option for STATIX tube stand configuration). Manual collimation is obviously always available.

## INNOVATIVE MOVING GRID WITH *INSTA*focus PENDULUM MOVEMENT (OPTIONAL)

The innovative *INSTA*focus moving grid system is available as optional on X-FRAME DR2S SYSTEM. This system, thanks to the proprietary pendulum grid movement that keeps the grid always in optimal focusing conditions with minimum absorption, guarantees a dose reduction of up to 18% with respect to traditional moving grids. In addition, the dose reduction is far greater when comparing to high-density stationary grids.

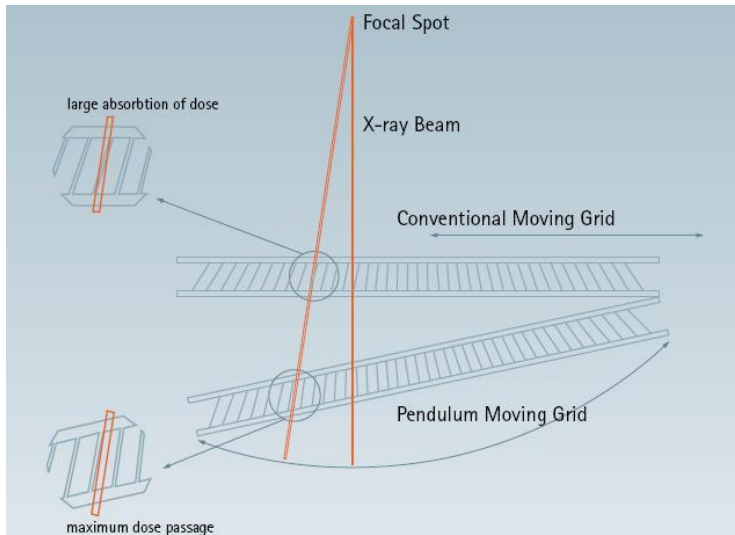

Moreover, thanks to the moving grid properties, there is no need to change the grid when moving from low SIDs (e.g. skull) to high SIDs (e.g. chest). Of course, the grid can always be removed if necessary for the specific exam (e.g. pediatric).

## EXAM-SPECIFIC SOFTWARE PACKAGES AND 16-BIT IMAGE ARCHIVE

X-FRAME DR2S SYSTEM is equipped with exam-specific software packages to perfectly fit each specific examination (chest, extremities, skull, etc.). So, whenever an individual exam type is selected, all detector acquisition parameters, pre-processing and post-processing image enhancement algorithms are automatically set to maximize image quality and diagnostic content. Moreover, images are stored with a gray level depth of 16-bit (65.536 levels of gray) thus guaranteeing maximum quality.

## IMAGE AVAILABLE IN LESS THAN 7 SECONDS

Less than 7 seconds after exposure, the diagnostic image (and not just a preview) is already available for quality control purposes on the acquisition workstation monitor: this is extremely important for emergency/trauma applications where clinical decisions have to be taken right away and there is no time to waste.



## PROPRIETARY HIERARCHIC everest-X IMAGE PROCESSING ENGINE

ITALRAY R&D Department has developed a proprietary image-processing engine to further enhance the image diagnostic content. Actually, DR images, thanks to their very wide dynamic range, contain detailed information in both high-attenuation image areas (shoulders, abdomen) and low-attenuation image areas (lungs, cavities).

This information is contained in the image pixel data but without advanced processing the operator must work with Window/Level to extract the clinical content. This means that, even if all the information is available, it is impossible to observe high-attenuation and low-attenuation image areas at the same time since they correspond to different zones of the grayscale.

With *everest-X*, it is now possible to expand the latitude of a single image and see all the relevant clinical details at the same time and without time-consuming Window/Level adjustment. This is made possible by hierarchically dividing the original image into a number of sub-images that each represent different spatial frequency bands and then smartly process/combine these sub-images in order to enhance the clinical content and increase the image diagnostic value.

Of course, since each specific examination (e.g. chest, abdomen, extremities, etc.) needs a specific algorithm tuning, just like the X-ray generator parameters, *everest-X* parameters are automatically set once the exam type has been downloaded from the RIS in the worklist.

The name *everest-X* has been chosen because the final image sits on the top of a hierarchic subdivision of the original image that reminds of a very tall mountain!



## NO MORE PATIENT RECALLS, NO MORE IMAGE RETAKES

With diagnostic images available in just 7 seconds, the operator can instantly verify if an image retake is necessary due to patient movement or other problems and the new image can be acquired instantly, without losing time in patient recalls.

In addition, thanks to the extremely wide detector dynamic range and to the advanced exam-specific software packages, even in case of X-ray parameters problems, image quality is always at diagnostic level thus eliminating the need for image retakes. Moreover, let us not forget that this also means reduced patient dose.

## MONOCHROME MEDICAL-GRADE LCD DISPLAY FOR MAXIMUM IMAGE CLARITY (OPTIONAL)

On the acquisition workstation is available, as option, a monochrome medical-grade 21,3" LCD monitor with high-brightness and providing maximum image clarity both for quality control and for diagnostic purposes (e.g. in emergency and trauma applications).

## NO TIME WASTED IN MANUAL PROCESSING

Collectively, all the smart automatic configuration and setup processes make sure that most images show the desired clinical content immediately and require no time consuming post-processing. Based on our experience with the units already installed, over 95% of the images need no manual post-processing made by the operator, and the remaining 5% need only minimal post-processing.

## POST PROCESSING TOOLS

The X-FRAME DR2S SYSTEM acquisition workstation is equipped with a complete range of post processing tools, such as Edge Enhancement, Infinite and Real Size Zoom, Window/Level Adjustment, just to name a few. Furthermore, annotation and measurement tools are also available with

## REDUNDANT HIGH-CAPACITY LOCAL IMAGE STORAGE

X-FRAME DR2S SYSTEM is equipped with a standard high-capacity local image archive, which is extremely important in case of momentary PACS unavailability or for stand-alone systems. The local archive can store up to 50.000 uncompressed 16-bit images or up to 100.000 compressed (lossless) 16-bit images. This is the equivalent of several weeks of work for the average installation.

Moreover, thanks to the redundant RAID1 mirroring configuration, images are stored at the same time on two separate parallel hard-drives, thus ensuring total data security.

## PERFORM AN ENTIRE EXAM IN FEW MINUTES

A full X-ray examination can be completed in few minutes: the only bottleneck will be the patient undressing/dressing time. Published studies demonstrate that the productivity of a DR room is at least 3 times higher than a standard X-ray room!

## DICOM INTEGRATION

Once the imaging session is completed, the entire study can be automatically sent to a PACS, a review workstation, or a DICOM printer; a large number of studies can be also maintained locally for temporary storage. Moreover, most importantly, the intuitive Graphical User Interface makes the entire process smooth and easy. The X-FRAME DR2S SYSTEM DICOM layer has been thoroughly tested and will seamlessly interface with any DICOM environment.

## STANDARD DICOM PART 14 CONFORMITY

X-FRAME DR is **DICOM Part 14 (Greyscale Standard Display Function) standard compliant**, this means that whenever X-Frame DR monitors are calibrated in accordance to this standard (by means of dedicated and specific tool) , acquired images are perfectly the same if shown either on the acquisition workstation or on any other DICOM Part 14 compliant display system, as for example, review station or DICOM Printer.

## DICOM PRINT COMPOSER WITH LIFESIZE PRINTING

Printing is made user friendly by the visual Print Composer that allows arranging study images in an intuitive manner. Lifesize printing is also supported, for orthopedic applications.

## SIGNIFICANT FILM AND CASSETTE-HANDLING SAVINGS

Furthermore, film-less operation allows major savings in terms of X-ray film and Printer film, not to mention the fact that bulky film developers are not needed anymore thus freeing up precious space and eliminating chemicals from the X-ray department.

Plus, since X-ray film handling (cassette preparation/handling, film development, film handling) is completely eliminated, with ITALRAY X-FRAME DR2S SYSTEM operators can now dedicate their entire time and attention to the actual X-ray exam with a consequent much improved patient care and personnel optimization.

## IMAGE STITCHING PACKAGE (OPTIONAL)



For full spine or full-extremity examination, X-FRAME DR-2T can be equipped with the optional **stitching** package which, thanks to the synchronized tube/detector movement, allows the operator to automatically take a number of adjacent images that are subsequently stitched together to provide a full-length image.

Italray has realized a rotational stitching: this means that the tube is kept fixed, and rotates just after any exposition, while the panel moves vertically behind the patient so that the x-ray beam is always centered with the panel.

For patient safety and to grant for his immobilization during the stitching image acquisition procedure, ITALRAY has equipped the X-FRAME DR2S SYSTEM room with a specific accessory for dedicated examinations.

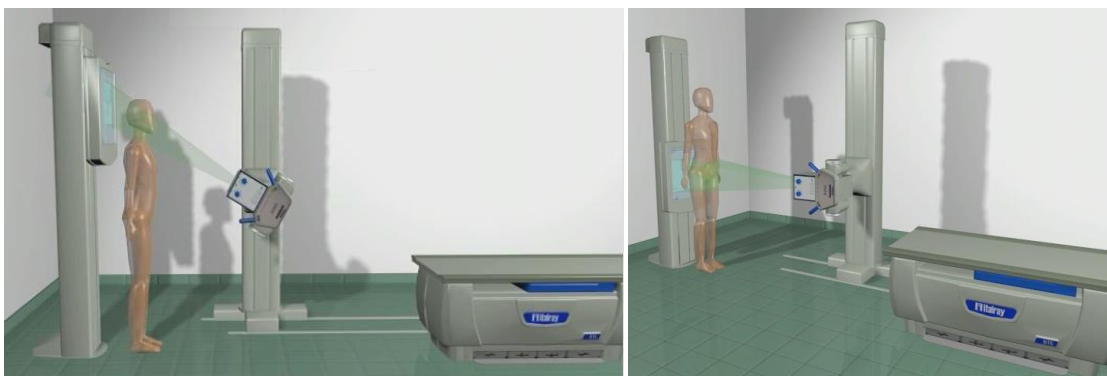

Rotational stitching in ITALRAY DR SOLUTIONS rooms

## GENERATOR-ONLY MODE

For maximum uptime, X-FRAME DR2S SYSTEM can always work with freestanding cassettes (film/CR) if necessary using the "Generator Only" option from the main GUI.

## MAXIMUM PRODUCTIVITY: IN OTHER WORDS ITALRAY X-FRAME DR2S SYSTEM

The ITALRAY X-FRAME DR2S SYSTEM room consists in the ITALRAY BS45 vertical stand, the ITALRAY STATIX SYNCHRO column tube stand and by the BTE elevating X-ray table.

X-FRAME DR2S SYSTEM guarantees the high throughput and workflow efficiency of a Dual Detector General X-ray room and has been designed to be extremely intuitive to use. Therefore, X-FRAME DR2S SYSTEM guarantees optimal performances in all working conditions while providing maximum flexibility for all necessary applications.

## AUTOMATIC VERTICAL TUBE DETECTOR CENTERING AND COLLIMATION

Vertical operation is extremely efficient thanks to the automatic motorized X-ray tube/detector centering which vastly improves the system throughput, and minimizes patient time in the X-ray room. Collimation is automatic motorized, according to the specific examination, patient size, and focal distance. Automatic centering and collimation work in both vertical and oblique examinations (this feature is an option for STATIX tube stand configuration).

Walk in, image, walk out, all in a few minutes and with no waste of time: that is what good patient care is also made of!

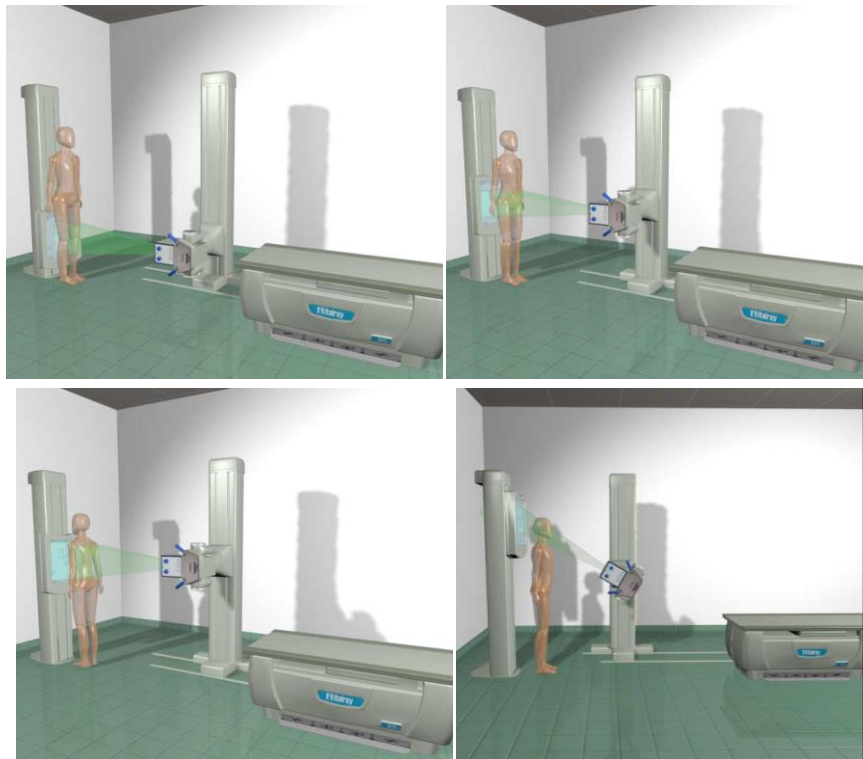

X-FRAME DR2S SYSTEM: automatic motorized tube-detector centering. For vertical and oblique examinations.

## AUTOMATIC COLLIMATOR LIGHT

Whenever the patient goes in front of the detector, an intelligently positioned sensor engages and activates the automatic collimator light allowing for immediate collimation verification. The collimator light is also automatically activated whenever a new projection is selected on the acquisition workstation thus allowing for instant collimation size verification (this feature is an option for STATIX tube stand configuration).



## SPECIAL COLLIMATION FOR PEDIATRIC PATIENTS

In case of chest examinations on pediatric patients, the collimation is aligned with the superior border of the detector and not centered on the detector center. This is done because for chest examinations the patient always has to position himself/herself with his/her chin on the detector superior border, but with pediatric patients, only the superior portion of the detector is actually used, and if the collimation were to be centered on the detector center, the patient would be exposed to unnecessary radiation (this feature is an option for STATIX tube stand configuration).

## BTE ELEVATING TABLE OPERATION

For standard X-ray procedures, the BTE elevating table provides the operator with a trusted and efficient system setup. Moreover, thanks to the very high level of system integration and to the multiple automatic functionalities, the overall workflow is optimized and productivity greatly enhanced.



## AUTOMATIC TUBE-DETECTOR VERTICAL FOCAL DISTANCE

The BTE tabletop is typically lowered to its minimum height to facilitate patient access (especially important with elderly/disabled patients). The tabletop is then raised again for easier exam execution. While the tabletop is being raised, the X-ray tube automatically maintains the desired focal distance thus freeing the operator from having to adjust it and therefore maximizing productivity, (this feature is an option for STATIX tube stand configuration).

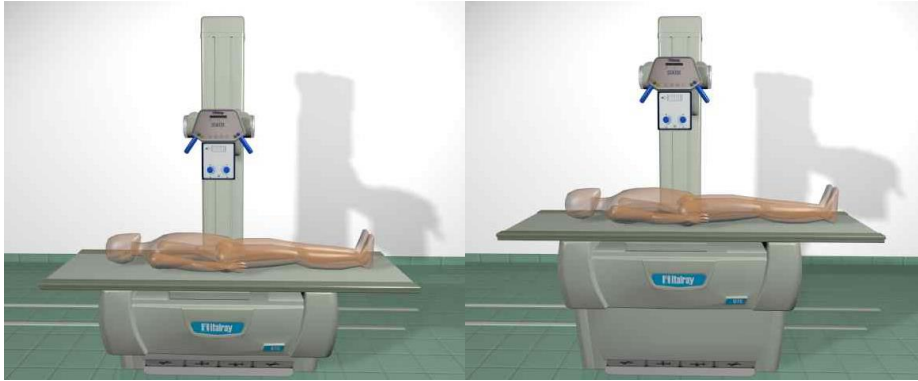

X-FRAME DR2S SYSTEM: automatic tube-detector vertical focal distance.

## AUTOMATIC HORIZONTAL TUBE DETECTOR CENTERING AND COLLIMATION

When performing examinations on the BTE elevating table, the detector automatically follows the X-ray tube movements thus guaranteeing exact tube-detector centering. Furthermore, the automatic motorized collimator adjusts the imaging area according to the chosen exam type, patient size, and focal distance. Automatic centering and collimation work in both horizontal and oblique examinations (this feature is an option for STATIX tube stand configuration).

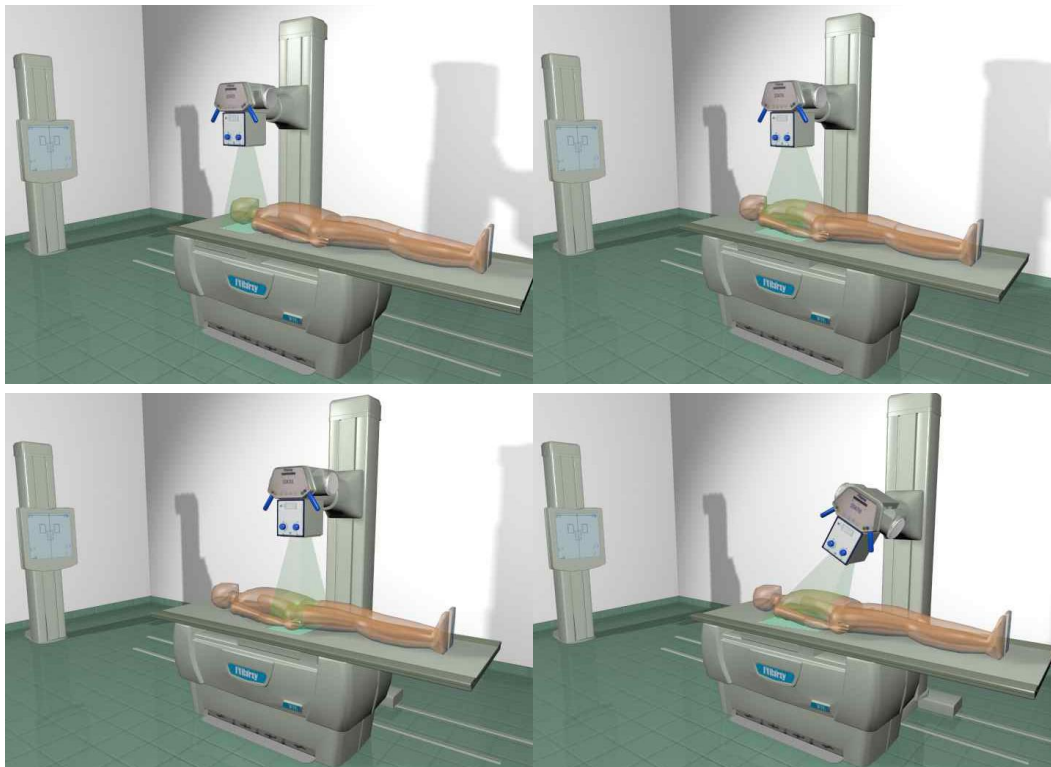

X-FRAME DR2S SYSTEM: automatic motorized tube-detector centering. For horizontal and oblique examinations.

## **COLLISION PREVENTION SYSTEM**

Because safety is paramount, automatic system mechanical movements are instantly blocked when the safety proximity sensor detects that there is an obstruction in the movement direction or when the force sensors detect an obstacle. Only after the obstruction has been removed, the system starts moving again. In addition, in order to make sure that everything is always under control, all movement have to be operator intentional.

## **REMOTE SERVICING**

X-FRAME DR2S SYSTEM is equipped with a remote servicing systems that allows ITALRAY service engineers to have access to the system via remote network for servicing or upgrading purposes. The remote servicing system availability is subordinate upon the technical/policy characteristics of the local Hospital network.

## **RELIABILITY AND SAFETY IN CASE OF BLACKOUTS (OPTION)**

X-FRAME DR can be equipped with an emergency power unit system (UPS) (option) that guarantees an autonomy of saving software data of more than 10 minutes, in order to protect the digital system from any voltage drop. This UPS ensures quality power to the load without interruptions, protecting from any kind of blackouts and filtering typical electrical noises in order to supply a perfect voltage to any loads. UPS battery starts working as soon as electrical mains drops, keeping constant the power supply to the load for its full operability. UPS autonomy grants for safe and controlled switch off digital main systems preventing any data loss or damage.

## TECHNICAL FEATURES

ACQUISITION SYSTEM				
IMAGE ACQUISITION & STORAGE	Fixed flat panel detector	Technology	Amorphous silicon	
		Scintillator	Gadox <sup>(2)</sup> (standard)/ CsI <sup>(1)</sup> (optional)	
		Resolution, Acquisition	2880 x 2880x16 bit	
		Resolution, Processing	2880 x 2880x16 bit	
		Pixel pitch	148 µm	
		Detector Dimensions	43x43 cm	
	Wireless cassette-size flat panel detector (optional)	Technology	Amorphous silicon	
		Scintillator	Gadox <sup>(2)</sup> (standard)/ CsI <sup>(1)</sup> (optional)	
		Resolution, Acquisition	2880x2400x16 bit	
		Resolution, Processing	2880x2400x16 bit	
		Pixel pitch	148 µm	
		Detector Dimensions	35x43 cm	
	DQE @ 0 lp/mm		66% max	
	Max images locally archived		50.000 images (no compression) 100.000 images (lossless compression)	
	Automatic LUT		YES, Linear and Logarithmic	
	Image Enhancement		YES, Automatic <i>Everest</i> -X	
	Anatomic Programs		YES, preconfigured and editable	
	Image Flip/Mirror		YES	
	R.O.I.		YES	
	Pan/Zoom		YES	
	Window/Level		YES	
	Automatic Window/Level		YES	
	Edge Enhancement		YES	
	Annotations		YES	
	Linear, angular measurements		YES	
	Greyscale Inversion		YES	
	Image Rotation		YES	
	Electronic Collimators		YES	
	Spatial Filters		YES	
	Multi-Images Visualization		YES	
Stitching		YES (optional)		
Grid control		YES, Automatic		
Grid type		Stationary (standard). Mobile <i>Instafocus</i> (optional)		
UPS		YES (optional)		

<sup>(1)</sup>Caesium Iodide<sup>(2)</sup>Gadolinium



ACQUISITION SYSTEM			
DICOM 3.0	Print SCU	YES, with Print Composer	
	Store SCU/SCP	YES	
	Worklist Management SCU	YES	
	Media Store SCU	YES (optional)	
	MPPS SCU	YES (optional)	
	Storage Commitment SCU	YES (optional)	
	Verification SCU/SCP	YES (optional)	
	Query/Retrieve SCU	YES (optional)	
	Greyscale Standard Display Function	YES (optional)	
WORKSTATION	Processor	Intel	
	Hard disks *	System hard disk: 250 GB Hard disk for image archive: 1 TB Mirror disk for recovery: 1 TB	
	Network*	Gigabit Ethernet	
	SO	Windows Embedded	
	Microphone with patient	YES, integrated (optional)	
	* Minimum granted requirements		
WORKSTATION DIMENSIONS	Length	550 mm	
	Width	700 mm	
	Height	1350 mm	
	Weight	100 kg	
STANDARD DISPLAY	Type	LCD colour	
	Dimensions	19,1"	
	Medical	YES; colour (standard)	
	Contrast	2000:1	
	Brightness	300 cd/m <sup>2</sup>	
	Suggested resolution	1280 x 1024	
OPTIONAL DISPLAY	Type	LCD Monochrome 2 MP	LCD Monochrome 3 MP
	Dimensions	21,3"	
	Medical	YES	
	Contrast	1400:1	
	Brightness	1200 cd/m <sup>2</sup>	
	Suggested resolution (pixel)	1200x1600	1536 x 2048

<b>X-ray GENERATOR</b>	
Generator type	High frequency with output up to 400 kHz
Power supply	380-400 Vac +/- 10%, 3 Ø + N
Line frequency	50/60 Hz
Output power	50 kW – 65 kW – 80 KW
kV range	40 - 150 kV. Precision: 1kV
mA range	16-630 mA; Precision: 11 steps (50 kW). 16-800 mA; Precision: 12 steps (65 kW). 16-1000 mA; Precision: 13 steps (80 kW).
Range mAs	0,4 - 1000 mAs
Time range	0,001 - 6,3 s. Precision: 39 steps.
Minimum mAs	0,4 mAs
HSS device	YES (optional)
Dose Meter	YES
AEC	YES
APR	More than 1100 anatomic programs. 3 points technique, 2 points technique, 1 point technique
Independent Operation	YES (X-ray Generator can also work independently with other imaging supports i.e. film and/or CR)
Generator Console	Integrated in the Acquisition Workstation (additional console optional)
Cabinet Dimensions (LxWxH)	500x457x1400 mm
Generator cabinet weight	135 kg min.

<b>X-RAY TUBE (STANDARD)</b>	
X-ray tube type	Rotating anode
Focal spots	2: 06x0,6 mm ( $P_{max}=35$ kW) e 1,2x1,2 mm ( $P_{max}=85$ kW)
Anode speed	3000 and 10.000 routes/min
Maximum voltage	150 kV
Anode heat capacity	300 kHU
Maximum heat dissipation	1.730 HU/s
Inherent filtration	0,7 mm Al @ 75 kV
Dose Area Product Meter (DAP)	YES, with dose information stored in image DICOM header (optional)

<b>X-RAY TUBE 1 (OPTIONAL)</b>	
X-ray tube type	Rotating anode
Focal spots	2: 06x0,6 mm ( $P_{max}=40$ kW) e 1,2x1,2 mm ( $P_{max}=100$ kW)
Anode speed	3000 and 10.000 routes/min
Maximum voltage	150 kV
Anode heat capacity	600 kHU
Maximum heat dissipation	2465 HU/s
Inherent filtration	1,1 mm Al @ 75 kV
Dose Area Product Meter (DAP)	YES, with dose information stored in image DICOM header (optional)

<b>X-RAY TUBE 2 (OPTIONAL)</b>	
X-ray tube type	Rotating anode
Focal spots	2: 06x0,6 mm ( $P_{max}=36$ kW) e 1,2x1,2 mm ( $P_{max}=96$ kW)
Anode speed	3000 and 10.000 routes/min
Maximum voltage	150 kV
Anode heat capacity	400 kHU
Maximum heat dissipation	1690 HU/s
Inherent filtration	1,1 mm Al @ 75 kV
Dose Area Product Meter (DAP)	YES, with dose information stored in image DICOM header (optional)

STATIX SYNCHRO X-RAY TUBE STAND	
Longitudinal Rails	2480 mm Front, 3000 mm Rear
Rails Height	20 mm
Longitudinal Travel	2076 mm
Longitudinal Movement	Manual
Column Height	2330 mm
Max X-ray Tube Focus Height	2008 mm
Min X-ray Tube Focus Height (Vertical beam)	418 mm
Min X-ray Tube Focus Height (Horizontal beam)	395 mm
Vertical Movement	Manual (standard) - Motorized with Automatic Detector Centering (and Automatic Focal Distance (optional))
Brakes Type	Electromechanical
Horizontal Axis Tube Rotation Angle	+/- 135° (mechanical stops every 90°)
Vertical Axis Tube Rotation Angle	+/- 90° (mechanical stops every 90°)
Collimator	Manual (standard) - Automatic Motorized (controlled by the acquisition workstation) with Automatic Light (optional)
Console	Handgrip with Ergonomic Controls
Console Display	LCD, with SID, linear, and angular position, and status/error messages
Weight	250 kg



<b>BS45 VERTICAL STAND</b>	
Column Height	2196 mm
Max Detector Center Height	2020 mm
Min Detector Center Height	440 mm
Vertical Movement	Manual Counterbalanced (Automatic Motorized optional)
Collision Detection	Proximity Sensor
Weight	200 kg
Detector Cover Al eq.	< 0.5 mm Al eq @ 70 kVp

<b>BTE ELEVATING TABLE</b>	
Tabletop Dimensions	2200 x 770 mm
Tabletop Longitudinal Travel	+/- 500 mm
Tabletop Transversal Travel	+/- 130 mm
Tabletop Surface-Detector Distance	68 mm
Detector Longitudinal Travel	400 mm – Motorized (optional)
Tabletop Height	550 – 885 mm – Motorized
Maximum patient weight for full performances	250 kg
Weight	250 kg
Tabletop Al eq.	0.5 mm Al eq @ 70 kVp

<b>POWER SUPPLY</b>	
X-Ray Generator	380 Vac +/- 10%, 50/60 Hz
System	230 Vac +/- 10%, 50/60 Hz

<b>ENVIRONMENT CONDITIONS</b>	
Operating Temperature	+10° / +40° C
Humidity	20% - 75% N.C.

ACCESSORIES

ACCESSORIES FOR BS45 VERTICAL BUCKY	
	<p>Grid holder</p>
	<p>Additional grid: F180 cm, 36 L/cm, R1:12</p>
	<p>Accessory for stitching exams: it supports the patient during several expositions. With double footrest and optional compression band.</p>

ACCESSORIES FOR BTE HORIZONTAL BUCKY	
	<p>Lateral wireless detector holder for lateral projection on lying patient.</p>

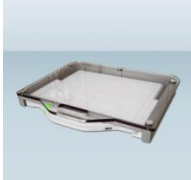
ACCESSORIES FOR WIRELESS DETECTOR	
	<p>Wireless detector holder for weight bearing examinations</p>

SIZE AND DIMENSIONS

BS45

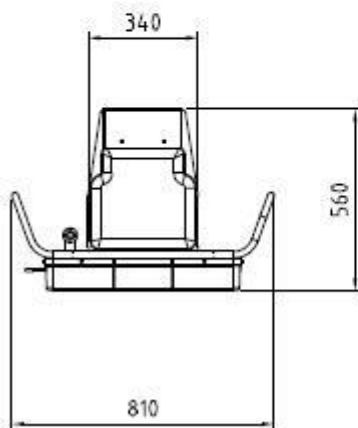
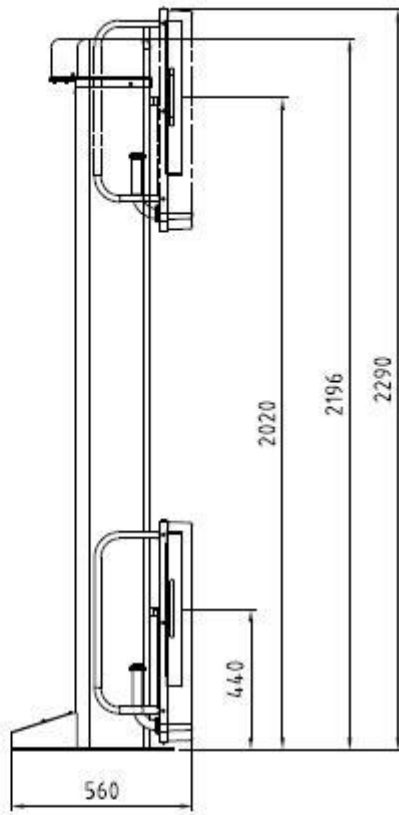
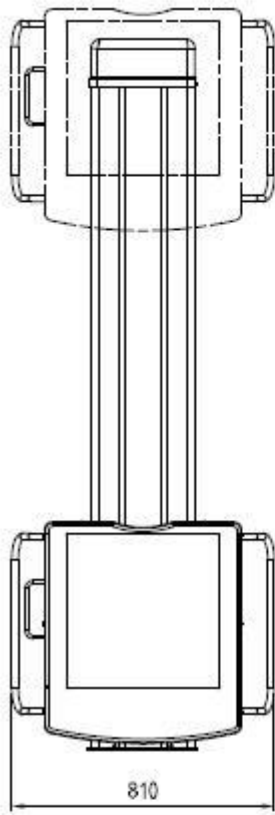

BTE

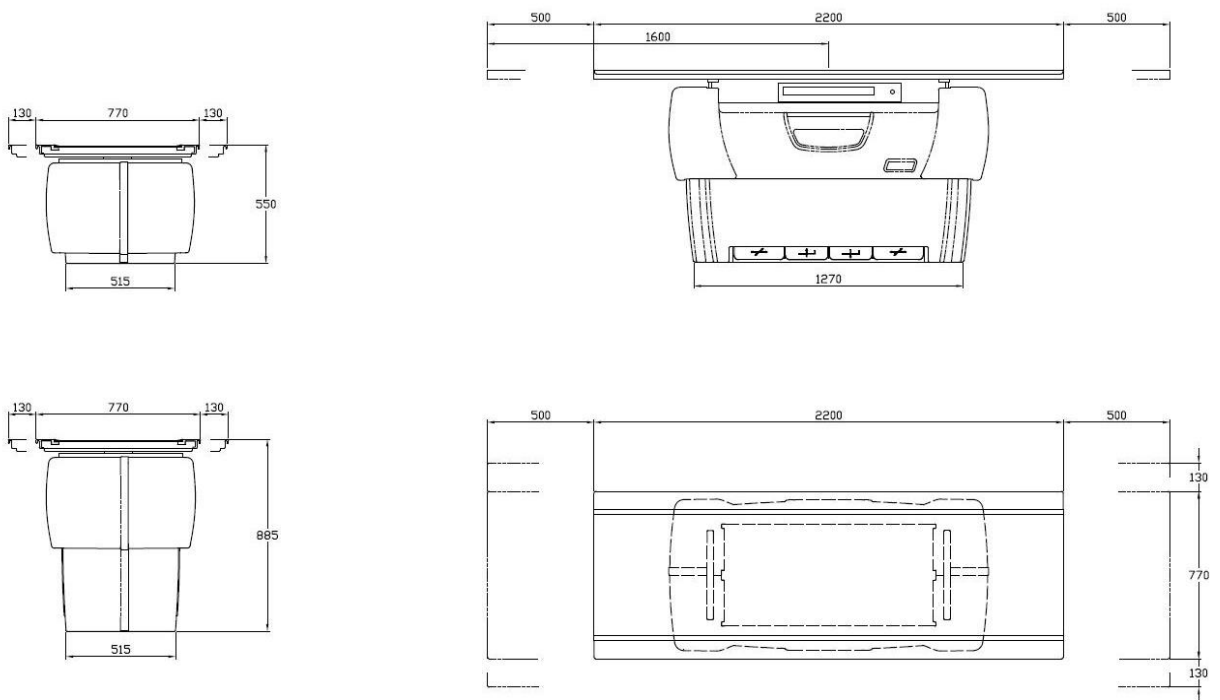



STATIX

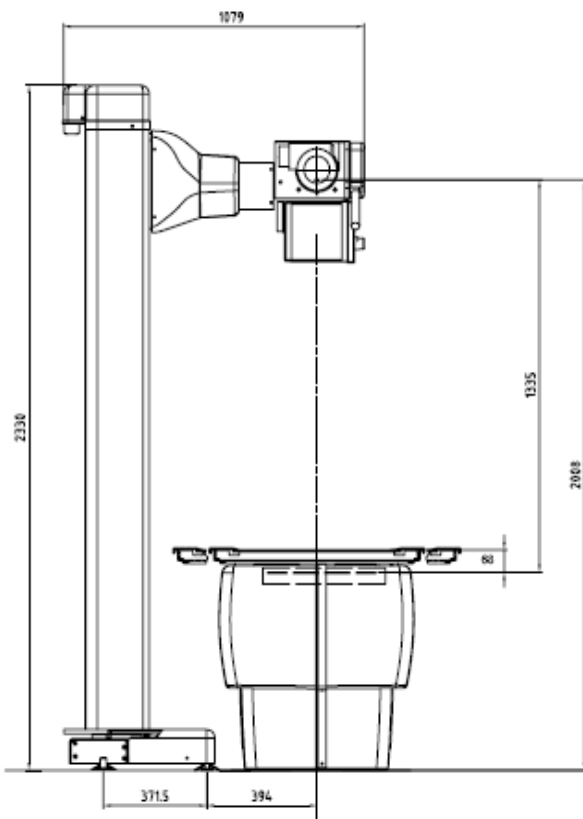
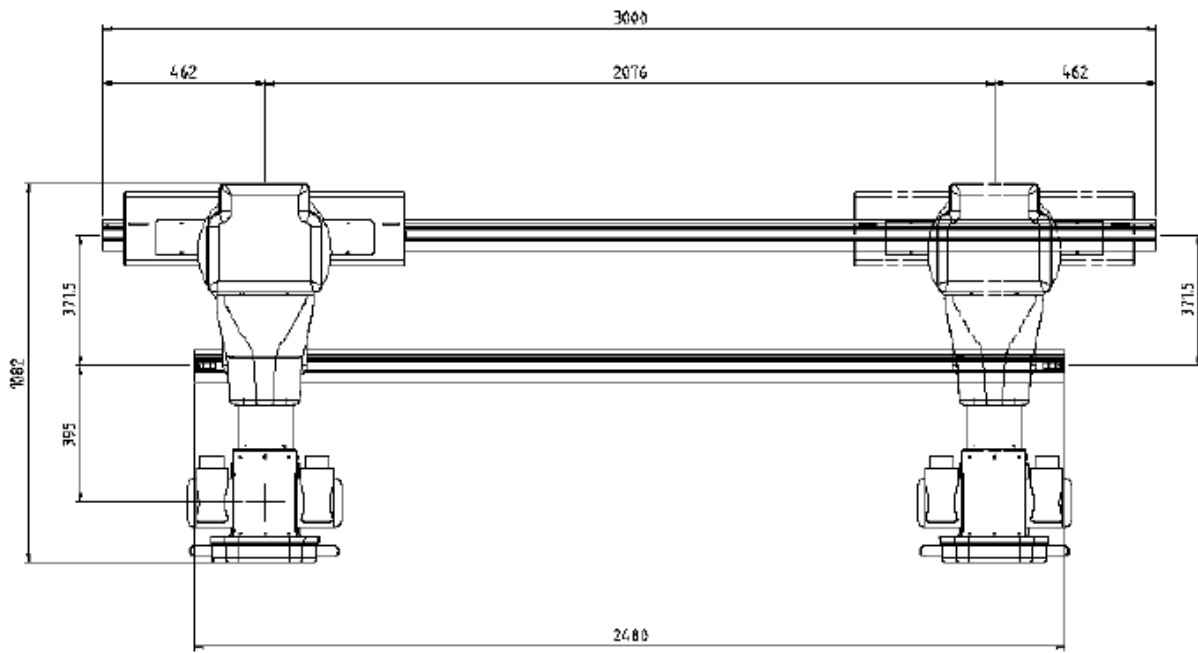

## CLASSIFICATIONS

According to European Directive 93/42 CEE X-FRAME DR2S SYSTEM is a class **II b** device. X-FRAME DR2S SYSTEM has been developed in compliance with the UNI EN ISO 9001:2008 and UNI EN ISO 13485:2012. Moreover, X-FRAME DR2S SYSTEM complies with the following Technical Norms: CEI EN 60601-series.

## INSTALLATION AND WARRANTY

**X-FRAME DR2S SYSTEM** can be installed only by authorized technical personnel that has been appropriately trained by ITALRAY. Upon request, ITALRAY Installation Office can prepare system installation layouts (including eventual construction/electrical).

ITALRAY guarantees its products for one year from the delivery date. ITALRAY can offer to its customers a wide range of service plans that will perfectly fit all needs and preferences.

ITALRAY DR Systems are equipped with a **remote service system** that allows ITALRAY service engineers to have access the system via remote network for servicing and upgrading purposes. The remote servicing system availability is subordinate upon the technical/policy characteristics of the local Hospital network.

ITALRAY reserves the right to make modifications without any prior notice.

